



Daniel Smith Industries Ltd

315 Flaxton Road, Rangiora, 7400
 Canterbury, New Zealand.
 Phone: 0064 (0) 3 313 9902
 Fax: 0064 (0) 3 313 9904
 Mobile 0064 (0) 21 33 66 23
 Email: daniel@danielsmith.co.nz
 Website: www.danielsmithindustries.co.nz



ICE 22-30

Hydraulic Vibratory Hammer

Vibrator: Model 22-30

Eccentric moment	25 kg-m
Max frequency	27 Hz
Centrifugal force	725 kN
Amplitude (free hanging)	23 mm
Max line pull for extracting	480 kN
Weight (no clamp or hoses)	3583 kg
Non-vibrating weight	1342 kg
Height (without clamp)	2032 mm
Length	1930 mm
Width	523 mm
Throat width	362 mm
Hydraulic hose length	46 m
Hydraulic hose weight	646 kg

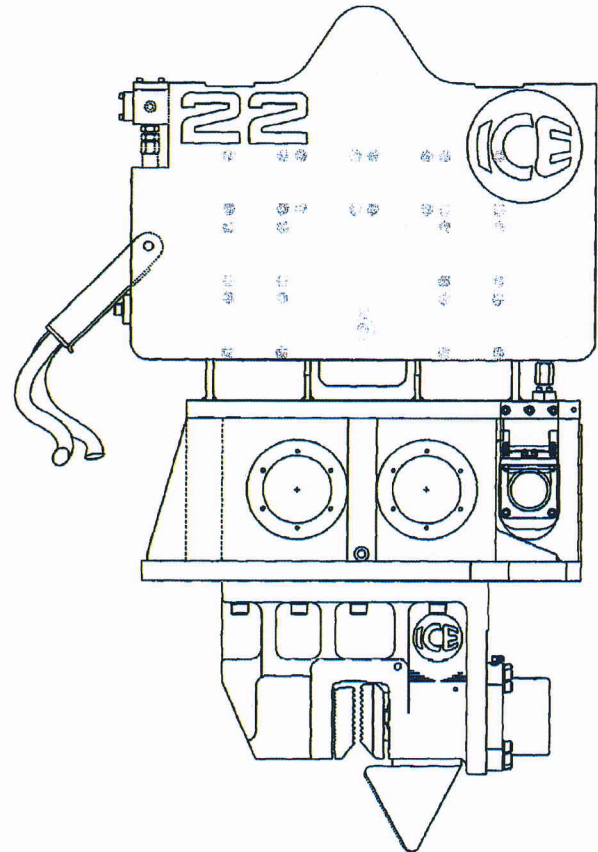

Power Unit:	Model 335E
Engine	Caterpillar C9
Power	335 HP/250 kW
Operating speed	2200 rpm
Max drive pressure	379 bar
Drive flow	344 lpm
Clamp pressure	331 bar
Clamp flow	24 lpm
Weight (w/ full fluid & fuel)	4741 kg
Length	3226 mm
Width	1626 mm
Height	1753 mm
Hydraulic reservoir	1041 liters
Fuel capacity	447 liters

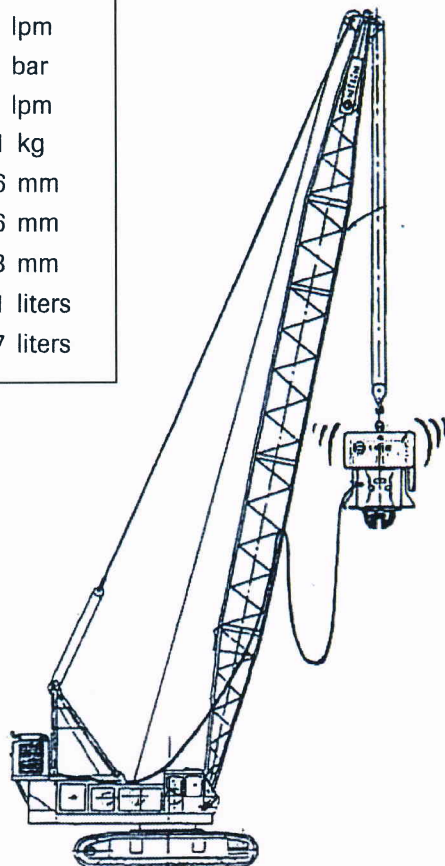

Clamps & Accessories

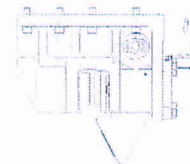

Model 126S
 Sheeting Clamp
 Clamp force 1112 kN
 Weight 991 kg

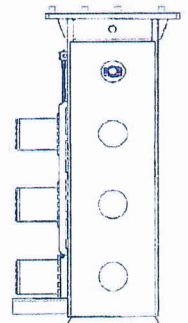

Model 180TP
 Pile Clamp
 Clamping force 1,800 kN
 Weight 3,000 kg

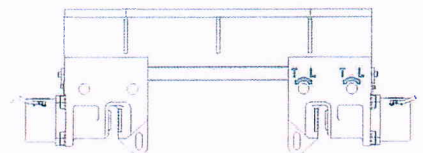

Model 80S Casing
 Clamps w/ 5' Beam
 Clamp force 1423 kN
 Weight 1279 kg